

Q-240R1



SVE BULLETIN

SPECIAL VEHICLE ENGINEERING – BODY BUILDERS ADVISORY SERVICE

E-Mail via Website: www.fleet.ford.com/truckbbas (click "Contact Us")

Toll-free: (877) 840-4338

QVM Bulletin: Q-240R1

Date: 14 September, 2015

Revised: 14 July, 2017

Guidance for Installing Aftermarket Transit Van Partitions / Bulkheads

Revision	Update	Revision Date
Q-240R1	• Included affected models up to current model year	14 July, 2017

Models Affected: Transit Vans, 2016 Model year and later.

Description:

Side curtain airbags are standard on Transit cargo vans starting 2016 model year. Upfitters installing aftermarket partitions / Bulkheads must insure that installations do not interfere with side curtain airbag deployment.

Medium and High Roof Recommendations:

Partitions or Bulkheads installed in Transit Vans must not interfere with airbag deployment zones. CAD of the Medium and High roof Airbag keep-out Zones is available upon request. Partition / Bulkhead should be positioned rearward of the prescribed keep-out zone.

Additionally, The RH / LH foam blocks cannot be removed or modified. To prevent damage to the deploying airbag, panel closeout around foam blocks should be a soft edge and the forward attaching face of the partition / bulkhead should have no exposed protruding fasteners or sharp edges.

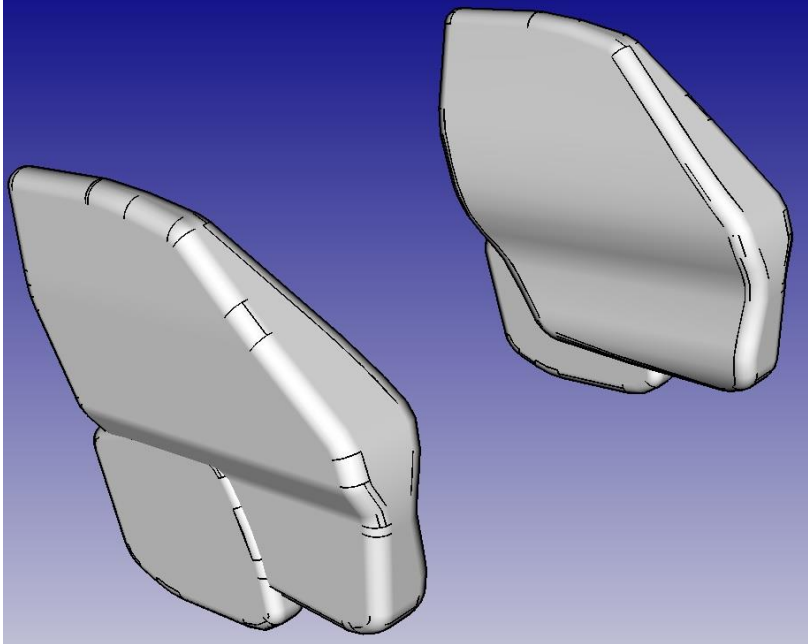

Figure 1: Airbag Keep-out zones (Medium and High roof)

Low roof recommendations:

Partitions and Bulkheads need to be positioned at or rearward of the front headliner / B-pillar trim surface while maintaining existing headliner and B-pillar surface. Bulkhead cannot attach directly to the headliner to ensure proper airbag deployment. . (See figures 2 and 3)

Additionally, The RH / LH foam blocks cannot be removed or modified. To prevent damage to the deploying airbag, panel closeout around foam blocks should be a soft edge and the forward attaching face of the partition / bulkhead should have no exposed protruding fasteners or sharp edges.

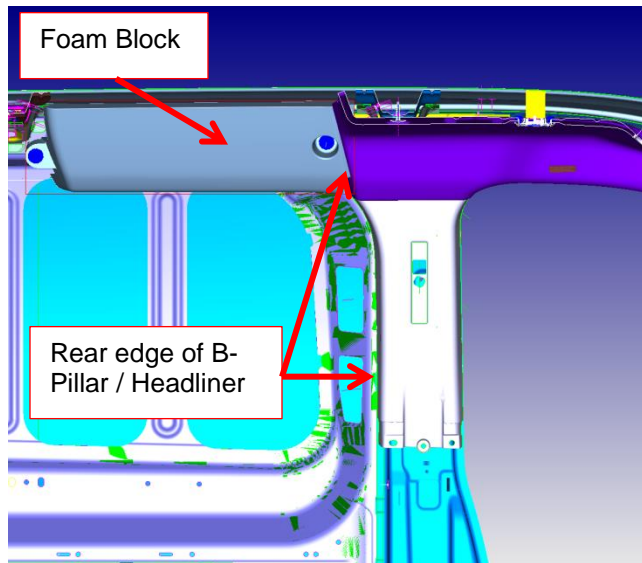

Figure 2

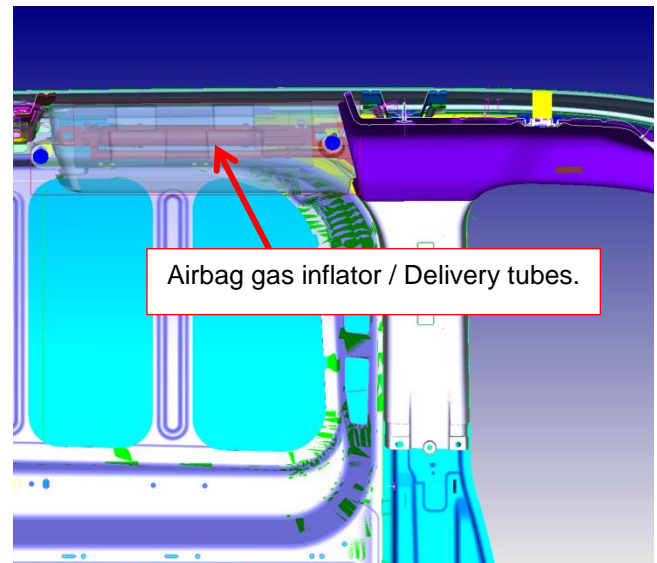

Figure 3

Seat Belt Retractor Damage

When fastening any aftermarket equipment to the B-pillar (such as a bulkhead partition), the modifier must ensure that drilling operations and/or fasteners do not damage the seatbelt retractor. Damage to the seat belt retractor caused by a vehicle modifier is not a warrantable charge.

Refer to SVE Bulletin Q-232 for more information.

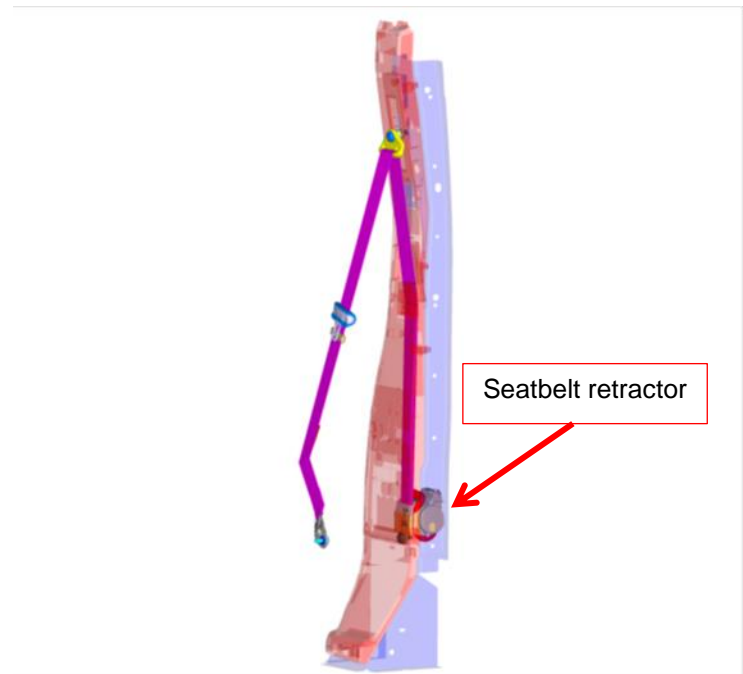

Figure 4: Seat Belt retractor location (Left side Shown)